

LINOVECTOR II

LV3-R / LV4-R
Copper/Aluminum and
Steel Element Ratings

Submittal

Specification

LV3 Slip Jointed Enclosure

ENCLOSURE:

- STYLE: Flat Top, Rounded Outlet
 OUTLET: Stamped Louvers
 Pencil Proof
- LENGTHS: 2'0" thru 8'0" in 6" Increments
 MAT'L: 16 Ga. CRS (Std)
 14 Ga. Aluminum (Opt'l)
 HEIGHT: 14"
 20" (LV4 only)
 24" (LV4 only)
 FINISH: Baked Powder (Std)
 Baked Metallic (Opt'l)

ACCESSORIES:

- LV Overlapping Type
 All accessories return to the wall at the bottom
 and have pre-punched holes for fastening to
 the wall.

ELEMENT:

- TYPE: Cu/AL (Mechanically
 Expanded)
 LENGTHS: 2'0" thru 12'6" in 1" Increments
 for 1" & 1-1/4" Cu.
 2'0" thru 8'0" in 1" Increments
 for 3/4" Cu.
 One End Flared (Std)
 TYPE: IPS Steel (Mechanically
 Expanded)
 LENGTHS: 2'0" thru 12'6" in 1" Increments
 NPT Thread both Ends (Std)
 Beveled Ends for Field Weld (Opt'l)

See Catalog for Working
 Pressures

LV4 Slip Jointed Enclosure

BACKPLATE:

- TYPE: Partial B/P
 LENGTHS: 8'0" Only
 MAT'L: 20 Ga. Prepainted (Std)
 18 Ga. Galvannealed (Opt'l)
 TYPE: Full Ht. B/P (Opt'l)
 LENGTHS: 2'0" thru 8'0" in 6" increments
 MAT'L: 20 Ga. Galvannealed (Opt'l)
 20 Ga. Painted (Opt'l)
 18 Ga. Painted (Opt'l)

AIRSEAL:

- 1/8" x 3/8" Closed Cell (Opt'l)

BRACKETS:

- Water Brkt w/B.B.
 Steam Brkt w/Brkt Mtd
 B.B. Hgr

DAMPER:

- Damper Blades Factory
 Installed
 Knob Damper (Opt'l)
 Tamper Resistant (Opt'l)

LV3-R14

ELEMENT TUBE SIZE	FIN SIZE HEIGHT x WIDTH	GRABLE NUMBER	A
3/4 COPPER	3 1/4 x 3 1/4	2	7"
1" COPPER	3 1/4 x 3 1/4	2	7 3/16
1 1/4 COPPER	3 1/4 x 3 1/4	1	6 5/8
1" STEEL	3 1/4 x 3 1/4	2	7 5/16
1 1/4 STEEL	3 1/4 x 3 1/4	1	6 13/16

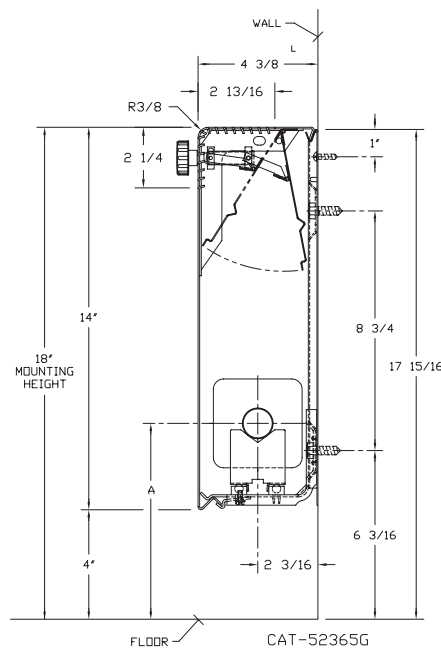

LV4-R14 20 24

ELEMENT TUBE SIZE	FIN SIZE HEIGHT x WIDTH	GRABLE NUMBER	A
3/4 COPPER	3 5/8 x 4 1/4	2	7"
3/4 COPPER	4 1/4 x 4 1/4	3A	7 3/8
1" COPPER	3 5/8 x 4 1/4	2	7 3/16
1" COPPER	4 1/4 x 4 1/4	2	7 3/16
1 1/4 COPPER	3 5/8 x 4 1/4	2	7 5/16
1 1/4 COPPER	4 1/4 x 4 1/4	2	7 5/16
1" STEEL	4 1/4 x 4 1/4	2	7 5/16
1 1/4 STEEL	4 1/4 x 4 1/4	2	7 1/2
2" STEEL	4 1/4 x 4 1/4	1	7 1/4

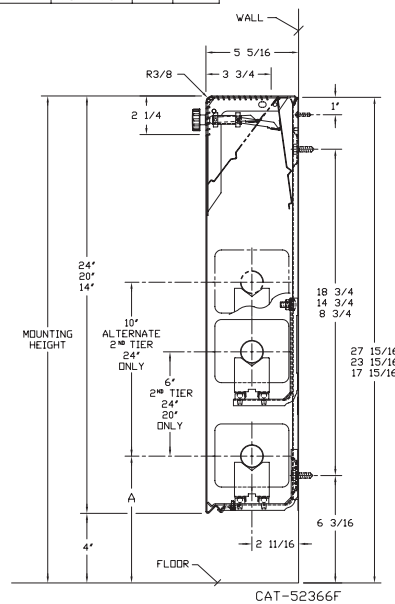

Vulcan

RADIATOR

260 North Elm St., Westfield, MA 01085
 (413) 568-9571 Fax: (413) 564-5661
 www.vulcanrad.com

PROJECT: _____ DATE: _____
 LOCATION: _____
 ARCHITECT: _____
 ENGINEER: _____
 CONTRACTOR: _____
 PO NUMBER: _____

STYLE "LV3-R / LV4-R" LINOVECTOR II

COPPER/ALUMINUM ELEMENTS

ALL RATINGS ARE IN BTU/HR/LIN FT AND BASED ON 3 FPS VELOCITY, 65° EAT

TUBE SIZE	CATALOG DESIGNATION	FIN SIZE HEIGHT X WIDTH	FINS PER FT.	FIN THICKNESS IN INCHES	ENCL HEIGHT IN INCHES	TIERS AND CENTERS IN INCHES	MOUNTING HEIGHT IN INCHES	STEAM 215° FACTOR	HOT WATER (AVG.)								
									200°	190°	180°	170°	160°	150°	140°	130°	120°
									CORRECTION FACTORS FOR AVERAGE WATER TEMPERATURES								1.00
3/4"	VC3/4-33	3-1/4" SQ.	32	.020	14	1	18	1070	920	830	740	650	570	480	430	350	280
3/4"	VC3/4-34	3-1/4" SQ.	40	.020	14	1	18	1240	1070	970	860	760	660	560	500	410	320
3/4"	VC3/4-35	3-1/4" SQ.	50	.020	14	1	18	1420	1220	1110	980	870	750	640	570	470	370
1"	VC33	3-1/4" SQ.	32	.020	14	1	18	1050	900	820	720	640	560	470	420	350	270
1"	VC34	3-1/4" SQ.	40	.020	14	1	18	1190	1020	930	820	730	630	540	480	390	310
1"	VC35	3-1/4" SQ.	50	.020	14	1	18	1430	1230	1120	990	870	760	640	570	470	370
1 1/4"	VC133	3-1/4" SQ.	32	.020	14	1	18	1010	870	790	700	620	540	450	400	330	260
1 1/4"	VC134	3-1/4" SQ.	40	.020	14	1	18	1120	960	870	770	680	590	500	450	370	290
1 1/4"	VC135	3-1/4" SQ.	50	.020	14	1	18	1340	1150	1050	920	820	710	600	540	440	350
3/4"	VC3/4-433	3-5/8" x 4-1/4"	32	.020	14	1	18	1405	1210	1100	970	860	740	630	560	460	370
					20	1	24	1490	1280	1160	1030	910	790	670	600	490	390
					20	2-6 CL	24	2140	1840	1670	1480	1310	1130	960	860	710	560
					24	1	28	1565	1350	1220	1080	950	830	700	630	520	410
					24	2-6 CL	28	2215	1900	1730	1530	1350	1170	1000	890	730	580
24	3-6 CL	28	2550	2190	1990	1760	1560	1350	1150	1020	840	660					
3/4"	VC3/4-434	3-5/8" x 4-1/4"	40	.020	14	1	18	1690	1450	1320	1170	1030	900	760	680	560	440
					20	1	24	1790	1540	1400	1240	1090	950	810	720	590	470
					20	2-6 CL	24	2490	2140	1940	1720	1520	1320	1120	1000	820	650
					24	1	28	1870	1610	1460	1290	1140	990	840	750	620	490
					24	2-6 CL	28	2590	2230	2020	1790	1580	1370	1170	1040	850	670
24	3-6 CL	28	2950	2540	2300	2040	1800	1560	1330	1180	970	770					
3/4"	VC3/4-435	3-5/8" x 4-1/4"	50	.020	14	1	18	1930	1660	1510	1330	1180	1020	870	770	640	500
					20	1	24	2110	1810	1650	1460	1290	1120	950	840	700	550
					20	2-6 CL	24	2640	2270	2060	1820	1610	1400	1190	1060	870	690
					24	1	28	2210	1900	1720	1520	1350	1170	990	880	730	570
					24	2-6 CL	28	2820	2430	2200	1950	1720	1490	1270	1130	930	730
24	3-6 CL	28	3190	2740	2490	2200	1950	1690	1440	1280	1050	830					
1"	VC433	3-5/8" x 4-1/4"	32	.020	14	1	18	1560	1340	1220	1080	950	830	700	620	510	410
					20	1	24	1610	1380	1260	1110	980	850	720	640	530	420
					20	2-6 CL	24	2480	2130	1930	1710	1510	1310	1120	990	820	640
					24	1	28	1650	1420	1290	1140	1010	870	740	660	540	430
					24	2-6 CL	28	2560	2200	2000	1770	1560	1360	1150	1020	840	670
24	3-6 CL	28	2940	2530	2290	2030	1790	1560	1320	1180	970	760					
1"	VC434	3-5/8" x 4-1/4"	40	.020	14	1	18	1770	1520	1380	1220	1080	940	800	710	580	460
					20	1	24	1880	1620	1470	1300	1150	1000	850	750	620	490
					20	2-6 CL	24	2600	2240	2030	1790	1590	1380	1170	1040	860	680
					24	1	28	1950	1680	1520	1350	1190	1030	880	780	640	510
					24	2-6 CL	28	2720	2340	2120	1880	1660	1440	1220	1090	900	710
24	3-6 CL	28	3100	2670	2420	2140	1890	1640	1400	1240	1020	810					
1"	VC435	3-5/8" x 4-1/4"	50	.020	14	1	18	2030	1750	1580	1400	1240	1080	910	810	670	530
					20	1	24	2220	1910	1730	1530	1350	1180	1000	890	730	580
					20	2-6 CL	24	2770	2380	2160	1910	1690	1470	1250	1110	910	720
					24	1	28	2330	2000	1820	1610	1420	1230	1050	930	770	610
					24	2-6 CL	28	2970	2550	2320	2050	1810	1570	1340	1190	980	770
24	3-6 CL	28	3360	2890	2620	2320	2050	1780	1510	1340	1110	870					
1-1/4"	VC1433	3-5/8" x 4-1/4"	32	.020	14	1	18	1530	1320	1190	1060	930	810	690	610	500	400
					20	1	24	1590	1370	1240	1100	970	840	720	640	520	410
					20	2 @ 6 CL	24	2470	2120	1930	1700	1510	1310	1110	990	820	640
					24	1	28	1630	1400	1270	1120	990	860	730	650	540	420
					24	2 @ 6 CL	28	2580	2220	2010	1780	1570	1370	1160	1030	850	670
24	3 @ 6 CL	28	2970	2550	2320	2050	1810	1570	1340	1190	980	770					
1-1/4"	VC1434	3-5/8" x 4-1/4"	40	.020	14	1	18	1750	1510	1370	1210	1070	930	790	700	580	460
					20	1	24	1850	1590	1440	1280	1130	980	830	740	610	480
					20	2 @ 6 CL	24	2620	2250	2040	1810	1600	1390	1180	1050	860	680
					24	1	28	1920	1650	1500	1320	1170	1020	860	770	630	500
					24	2 @ 6 CL	28	2750	2370	2150	1900	1680	1460	1240	1100	910	720
24	3 @ 6 CL	28	3130	2690	2440	2160	1910	1660	1410	1250	1030	810					
1-1/4"	VC1435	3-5/8" x 4-1/4"	50	.020	14	1	18	2040	1750	1590	1410	1240	1080	920	820	670	530
					20	1	24	2240	1930	1750	1550	1370	1190	1010	900	740	580
					20	2 @ 6 CL	24	2730	2350	2130	1880	1670	1450	1230	1090	900	710
					24	1	28	2380	2050	1860	1640	1450	1260	1070	950	790	620
					24	2 @ 6 CL	28	3000	2580	2340	2070	1830	1590	1350	1200	990	780
24	3 @ 6 CL	28	3390	2920	2640	2340	2070	1800	1530	1360	1120	880					

STYLE "LV3-R / LV4-R" LINOVECTOR II

COPPER/ALUMINUM ELEMENTS

ALL RATINGS ARE IN BTU/HR/LIN FT AND BASED ON 3 FPS VELOCITY, 65° EAT

TUBE SIZE	CATALOG DESIGNATION	FIN SIZE HEIGHT X WIDTH	FINS PER FT.	FIN THICKNESS IN INCHES	ENCL HEIGHT IN INCHES	TIERS AND CENTERS IN INCHES	MOUNTING HEIGHT IN INCHES	STEAM 215° FACTOR	HOT WATER (AVG.)																		
									200°	190°	180°	170°	160°	150°	140°	130°	120°	CORRECTION FACTORS FOR AVERAGE WATER TEMPERATURES									
									1.00	0.86	0.78	0.69	0.61	0.53	0.45	.40	.33	.26									
3/4"	VC3/4-43	4-1/4" SQ.	32	.020	14	1	18	1520	1310	1190	1050	930	810	680	610	500	400										
					20	1	24	1615	1390	1260	1110	990	860	730	650	530	420										
					20	2-6 CL	24	2345	2020	1830	1620	1430	1240	1060	940	770	610										
					24	1	28	1685	1450	1310	1160	1030	890	760	670	560	440										
					24	2-6 CL	28	2435	2090	1900	1680	1490	1290	1100	970	800	630										
24	3-6 CL	28	2800	2410	2180	1930	1710	1480	1260	1120	920	730															
3/4"	VC3/4-44	4-1/4" SQ.	40	.020	14	1	18	2100	1810	1640	1450	1280	1110	950	840	690	550										
					20	1	24	2250	1940	1760	1550	1370	1190	1010	900	740	590										
					20	2-6 CL	24	3180	2730	2480	2190	1940	1690	1430	1270	1050	830										
					24	1	28	2350	2020	1830	1620	1430	1250	1060	940	780	610										
					24	2-6 CL	28	3270	2810	2550	2260	1990	1730	1470	1310	1080	850										
24	3-6 CL	28	3730	3210	2910	2570	2280	1980	1680	1490	1230	970															
3/4"	VC3/4-45	4-1/4" SQ.	50	.020	14	1	18	2210	1900	1720	1520	1350	1170	990	880	730	570										
					20	1	24	2420	2080	1890	1670	1480	1280	1090	970	800	630										
					20	2-6 CL	24	3200	2750	2500	2210	1950	1700	1440	1280	1060	830										
					24	1	28	2550	2190	1990	1760	1560	1350	1150	1020	840	660										
					24	2-6 CL	28	3380	2910	2640	2330	2060	1790	1520	1350	1120	880										
24	3-6 CL	28	3820	3290	2980	2640	2330	2020	1720	1530	1260	990															
1"	VC43	4-1/4" SQ.	32	.020	14	1	18	1710	1470	1330	1180	1040	910	770	680	560	440										
					20	1	24	1760	1510	1370	1210	1070	930	790	700	580	460										
					20	2-6 CL	24	2720	2340	2120	1880	1660	1440	1220	1090	900	710										
					24	1	28	1810	1560	1410	1250	1100	960	810	720	600	470										
					24	2-6 CL	28	2810	2420	2190	1940	1710	1490	1260	1120	930	730										
24	3-6 CL	28	3230	2780	2520	2230	1970	1710	1450	1290	1070	840															
1"	VC44	4-1/4" SQ.	40	.020	14	1	18	1940	1670	1510	1340	1180	1030	870	780	640	500										
					20	1	24	2070	1780	1610	1430	1260	1100	930	830	680	540										
					20	2-6 CL	24	2850	2450	2220	1970	1740	1510	1280	1140	940	740										
					24	1	28	2140	1840	1670	1480	1310	1130	960	860	710	560										
					24	2-6 CL	28	2990	2570	2330	2060	1820	1580	1350	1200	990	780										
24	3-6 CL	28	3410	2930	2660	2350	2080	1810	1530	1360	1130	890															
1"	VC45	4-1/4" SQ.	50	.020	14	1	18	2220	1910	1730	1530	1350	1180	1000	890	730	580										
					20	1	24	2430	2090	1900	1680	1480	1290	1090	970	800	630										
					20	2-6 CL	24	3030	2610	2360	2090	1850	1610	1360	1210	1000	790										
					24	1	28	2550	2190	1990	1760	1560	1350	1150	1020	840	660										
					24	2-6 CL	28	3250	2800	2540	2240	1980	1720	1460	1300	1070	850										
24	3-6 CL	28	3670	3160	2860	2530	2240	1950	1650	1470	1210	950															
1-1/4"	VC143	4-1/4" SQ.	32	.020	14	1	18	1700	1460	1330	1170	1040	900	770	680	560	440										
					20	1	24	1740	1500	1360	1200	1060	920	780	700	570	450										
					20	2-6 CL	24	2670	2300	2080	1840	1630	1420	1200	1070	880	690										
					24	1	28	1780	1530	1390	1230	1090	940	800	710	590	460										
					24	2-6 CL	28	2720	2340	2120	1880	1660	1440	1220	1090	900	710										
24	3-6 CL	28	3130	2690	2440	2160	1910	1660	1410	1250	1030	810															
1-1/4"	VC144	4-1/4" SQ.	40	.020	14	1	18	1950	1680	1520	1350	1190	1030	880	780	640	510										
					20	1	24	2090	1800	1630	1440	1270	1110	940	840	690	540										
					20	2-6 CL	24	2810	2420	2190	1940	1710	1490	1260	1120	930	730										
					24	1	28	2160	1860	1680	1490	1320	1140	970	860	710	560										
					24	2-6 CL	28	2940	2530	2290	2030	1790	1560	1320	1180	970	760										
24	3-6 CL	28	3350	2880	2610	2310	2040	1780	1510	1340	1110	870															
1-1/4"	VC145	4-1/4" SQ.	50	.020	14	1	18	2100	1810	1640	1450	1280	1110	950	840	690	550										
					20	1	24	2300	1980	1790	1590	1400	1220	1040	920	760	600										
					20	2-6 CL	24	2940	2530	2290	2030	1790	1560	1320	1180	970	760										
					24	1	28	2380	2050	1860	1640	1450	1260	1070	950	790	620										
					24	2-6 CL	28	3060	2630	2390	2110	1870	1620	1380	1220	1010	800										
24	3-6 CL	28	3460	2980	2700	2390	2110	1830	1560	1380	1140	900															

Note: Copper tube furnished flared one end standard.

STYLE "LV3-R / LV4-R" LINOVECTOR II

STEEL ELEMENTS

ALL RATINGS ARE IN BTU/HR/LIN FT AND BASED ON 3 FPS VELOCITY, 65° EAT

TUBE SIZE	CATALOG DESIGNATION	FIN SIZE HEIGHT X WIDTH	FINS PER FT.	FIN THICKNESS IN INCHES	ENCL HEIGHT IN INCHES	TIERS AND CENTERS IN INCHES	MOUNTING HEIGHT IN INCHES	STEAM 215° FACTOR	HOT WATER (AVG.)																		
									200°	190°	180°	170°	160°	150°	140°	130°	120°	CORRECTION FACTORS FOR AVERAGE WATER TEMPERATURES									
									1.00	0.86	0.78	0.69	0.61	0.53	0.45	.40	.33	.26									
1"	VS33	3-1/4" SQ.	32	.032	14	1	18	1000	860	780	690	610	530	450	400	330	260										
1"	VS34	3-1/4" SQ.	40	.032	14	1	18	1100	950	860	760	670	580	500	440	360	290										
1"	VS35	3-1/4" SQ.	50	.032	14	1	18	1170	1010	910	810	710	620	530	470	390	300										
1-1/4"	VS133	3-1/4" SQ.	32	.032	14	1	18	990	850	770	680	600	520	450	400	330	260										
1-1/4"	VS134	3-1/4" SQ.	40	.032	14	1	18	1120	960	870	770	680	590	500	450	370	290										
1-1/4"	VS135	3-1/4" SQ.	50	.032	14	1	18	1150	990	900	790	700	610	520	460	380	300										
1"	VS43	4-1/4" SQ.	32	.032	14	1	18	1430	1230	1120	990	870	760	640	570	470	370										
					20	1	24	1480	1270	1150	1020	900	780	670	590	490	380										
					20	2-6 CL	24	2215	1900	1730	1530	1350	1170	1000	890	730	580										
					24	1	28	1520	1310	1190	1050	930	810	680	610	500	400										
					24	2-6 CL	28	2255	1940	1760	1560	1380	1200	1010	900	740	590										
24	3-6 CL	28	2590	2230	2020	1790	1580	1370	1170	1040	850	670															
1"	VS44	4-1/4" SQ.	40	.032	14	1	18	1605	1380	1250	1110	980	850	720	640	530	420										
					20	1	24	1705	1470	1330	1180	1040	900	770	680	560	440										
					20	2-6 CL	24	2395	2060	1870	1650	1460	1270	1080	960	790	620										
					24	1	28	1765	1520	1380	1220	1080	940	790	710	580	460										
					24	2-6 CL	28	2470	2120	1930	1700	1510	1310	1110	990	820	640										
24	3-6 CL	28	2820	2430	2200	1950	1720	1490	1270	1130	930	730															
1"	VS45	4-1/4" SQ.	50	.032	14	1	18	1680	1440	1310	1160	1020	890	760	670	550	440										
					20	1	24	1785	1540	1390	1230	1090	950	800	710	590	460										
					20	2-6 CL	24	2455	2110	1910	1690	1500	1300	1100	980	810	640										
					24	1	28	1850	1590	1440	1280	1130	980	830	740	610	480										
					24	2-6 CL	28	2535	2180	1980	1750	1550	1340	1140	1010	840	660										
24	3-6 CL	28	2860	2460	2230	1970	1740	1520	1290	1140	940	740															
1-1/4"	VS143	4-1/4" SQ.	32	.032	14	1	18	1300	1120	1010	900	790	690	590	520	430	340										
					20	1	24	1310	1130	1020	900	800	690	590	520	430	340										
					20	2-6 CL	24	2070	1780	1610	1430	1260	1100	930	830	680	540										
					24	1	28	1320	1140	1030	910	810	700	590	530	440	340										
					24	2-6 CL	28	2120	1820	1650	1460	1290	1120	950	850	700	550										
24	3-6 CL	28	2440	2100	1900	1680	1490	1290	1100	980	810	630															
1-1/4"	VS144	4-1/4" SQ.	40	.032	14	1	18	1540	1320	1200	1060	940	820	690	620	510	400										
					20	1	24	1620	1390	1260	1120	990	860	730	650	530	420										
					20	2-6 CL	24	2400	2060	1870	1660	1460	1270	1080	960	790	620										
					24	1	28	1680	1440	1310	1160	1020	890	760	670	550	440										
					24	2-6 CL	28	2510	2160	1960	1730	1530	1330	1130	1000	830	650										
24	3-6 CL	28	2860	2460	2230	1970	1740	1520	1290	1140	940	740															
1-1/4"	VS145	4-1/4" SQ.	50	.032	14	1	18	1670	1440	1300	1150	1020	890	750	670	550	430										
					20	1	24	1775	1530	1380	1220	1080	940	800	710	590	460										
					20	2-6 CL	24	2405	2070	1880	1660	1470	1270	1080	960	790	630										
					24	1	28	1835	1580	1430	1270	1120	970	830	730	610	480										
					24	2-6 CL	28	2485	2140	1940	1710	1520	1320	1120	990	820	650										
24	3-6 CL	28	2810	2420	2190	1940	1710	1490	1260	1120	930	730															
2"	VS242	4-1/4" SQ.	25	.032	14	1	18	1230	1060	960	850	750	650	550	490	410	320										
					20	1	24	1240	1070	970	860	760	660	560	500	410	320										
					20	2-6 CL	24	1940	1670	1510	1340	1180	1030	870	780	640	500										
					24	1	28	1250	1080	980	860	760	660	560	500	410	330										
					24	2-6 CL	28	2000	1720	1560	1380	1220	1060	900	800	660	520										
24	3-6 CL	28	2300	1980	1790	1590	1400	1220	1040	920	760	600															
2"	VS243	4-1/4" SQ.	32	.032	14	1	18	1420	1220	1110	980	870	750	640	570	470	370										
					20	1	24	1460	1260	1140	1010	890	770	660	580	480	380										
					20	2-6 CL	24	2140	1840	1670	1480	1310	1130	960	860	710	560										
					24	1	28	1480	1270	1150	1020	900	780	670	590	490	380										
					24	2-6 CL	28	2220	1910	1730	1530	1350	1180	1000	890	730	580										
24	3-6 CL	28	2550	2190	1990	1760	1560	1350	1150	1020	840	660															

- Notes: 1) Steel fins furnished as .032 thick, painted black.
 2) NPT threads furnished on steel elements. Please use domestic fittings for proper installation.
 3) The ends can be provided chamfered for field welded fittings when specified.

Steam Bracket and BB Hanger

ELEMENT TUBE SIZE	FIN SIZE HEIGHT x WIDTH	CRADLE NUMBER	A MIN	A MAX
3/4 COPPER	3 1/4 x 3 1/4	2	7 3/8	9 5/8
1" COPPER	3 1/4 x 3 1/4	2	7 1/2	9 3/4
1 1/4 COPPER	3 1/4 x 3 1/4	2	7 5/8	9 7/8
1" STEEL	3 1/4 x 3 1/4	2	7 5/8	9 3/4
1 1/4 STEEL	3 1/4 x 3 1/4	1	7 3/16	9 3/8

ELEMENT TUBE SIZE	FIN SIZE HEIGHT x WIDTH	CRADLE NUMBER	A MIN	A MAX
3/4 COPPER	3 5/8 x 4 1/4	2	7 3/8	8 3/4
	4 1/4 x 4 1/4	3A	7 11/16	9 1/16
1" COPPER	3 5/8 x 4 1/4	2	7 1/2	8 7/8
	4 1/4 x 4 1/4			
1 1/4 COPPER	3 5/8 x 4 1/4	2	7 5/8	9"
	4 1/4 x 4 1/4			
1" STEEL	4 1/4 x 4 1/4	2	7 5/8	9"
1 1/4 STEEL	4 1/4 x 4 1/4	2	7 7/8	9 1/4
2" STEEL	4 1/4 x 4 1/4	1	7 5/8	9"

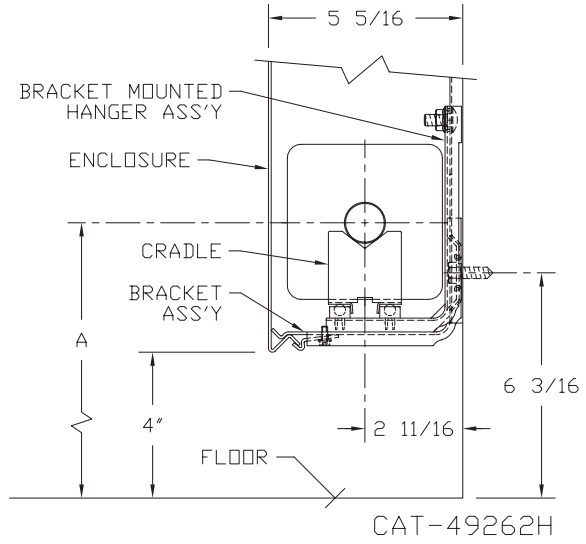
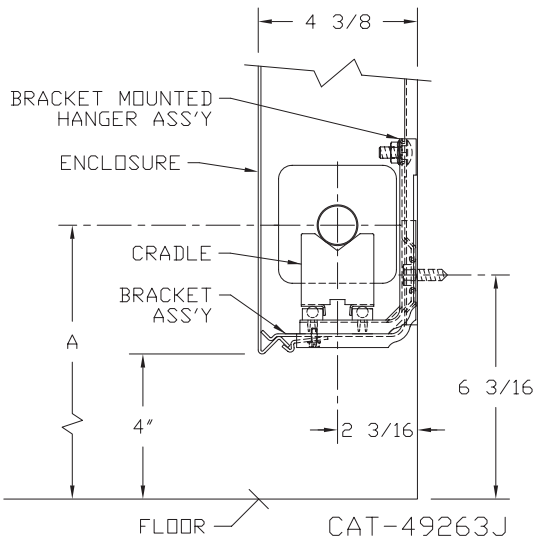

Design Data

COMMERCIAL FINNED TUBE CHARTS FOR RATING CORRECTIONS

For assistance with ratings and selection, please use our online Specifier.

CORRECTION FACTORS FOR WATER TEMPERATURES AND AIR TEMPERATURES OTHER THAN STANDARD															
AVERAGE WATER TEMP. °F	ENTERING AIR TEMPERATURE °F														
	45	55	STD 65	70	75	80	85	90	95	100	110	120	130	140	150
90	.19	.13	.11	.06											
100	.25	.19	.15	.11	.08	.06									
110	.31	.25	.20	.16	.13	.11	.08	.06							
120	.38	.31	.26	.21	.19	.16	.13	.11	.08	.06					
130	.45	.38	.33	.28	.25	.21	.19	.16	.13	.11	.06				
140	.53	.45	.40	.34	.31	.28	.25	.21	.19	.16	.11	.06			
150	.61	.53	.45	.41	.38	.34	.31	.28	.25	.21	.16	.11	.06		
160	.69	.61	.53	.49	.45	.41	.38	.34	.31	.28	.21	.16	.11	.06	
170	.77	.69	.61	.57	.53	.49	.45	.41	.38	.34	.28	.21	.16	.11	.06
180	.86	.77	.69	.65	.61	.57	.53	.49	.45	.41	.34	.28	.21	.16	.11
190	.95	.86	.78	.73	.69	.65	.61	.57	.53	.49	.41	.34	.28	.21	.16
200	1.05	.95	.86	.82	.77	.73	.69	.65	.61	.57	.49	.41	.34	.28	.21
210	1.14	1.05	.95	.91	.86	.82	.77	.73	.69	.65	.57	.49	.41	.34	.28
▶ 215 (STD.)	1.19	1.09	1.00	.95	.91	.86	.82	.77	.73	.69	.61	.53	.45	.38	.31
220	1.24	1.14	1.05	1.00	.95	.91	.86	.82	.77	.73	.65	.57	.49	.41	.34
230	1.34	1.24	1.14	1.09	1.05	1.00	.95	.91	.86	.82	.73	.65	.57	.49	.41
240	1.44	1.34	1.25	1.19	1.14	1.09	1.05	1.00	.95	.91	.82	.73	.65	.57	.49
250	1.55	1.44	1.34	1.29	1.24	1.19	1.14	1.09	1.05	1.00	.91	.82	.73	.65	.57
260	1.66	1.55	1.44	1.39	1.34	1.29	1.24	1.19	1.14	1.09	1.00	.91	.82	.73	.65
270	1.76	1.66	1.55	1.50	1.44	1.39	1.34	1.29	1.24	1.19	1.09	1.00	.91	.82	.73
280	1.87	1.76	1.66	1.60	1.55	1.50	1.44	1.39	1.34	1.29	1.19	1.09	1.00	.91	.82
290	1.99	1.87	1.76	1.71	1.66	1.60	1.55	1.50	1.44	1.39	1.29	1.19	1.09	1.00	.91
300	2.10	1.99	1.87	1.82	1.76	1.71	1.66	1.60	1.55	1.50	1.39	1.29	1.19	1.09	1.00

CORRECTION FACTORS FOR STEAM PRESSURES AND AIR TEMPERATURES OTHER THAN STANDARD																
STEAM		ENTERING AIR TEMPERATURE °F														
PRESSURE		TEMP. °F	45	55	STD 65	70	75	80	85	90	100	110	120	130	140	150
GAUGE	ABS. PSI															
(VAC) 15" HG	7.32	178.9	0.90	0.80	0.70	0.65	0.60	0.56	0.51	0.45	0.39	0.32	0.25	0.18	0.13	0.08
(VAC) 10"	9.78	192.2	1.02	0.91	0.81	0.76	0.71	0.66	0.62	0.55	0.48	0.40	0.33	0.26	0.20	0.14
(VAC) 5"	12.25	202.9	1.11	1.00	0.90	0.85	0.79	0.75	0.70	0.63	0.56	0.48	0.40	0.33	0.27	0.20
▶ 0 PSI	14.696	212.0	1.19	1.09	0.97	0.92	0.87	0.82	0.77	0.70	0.63	0.54	0.46	0.38	0.31	0.25
.899	15.595	215.0	1.22	1.11	1.00	0.95	0.90	0.84	0.80	0.75	0.65	0.57	0.48	0.40	0.33	0.26
5	19.70	227.1	1.34	1.22	1.11	1.05	1.00	0.95	0.90	0.81	0.75	0.66	0.57	0.49	0.41	0.34
10	24.70	239.4	1.45	1.33	1.22	1.17	1.11	1.05	1.00	0.91	0.85	0.75	0.66	0.58	0.50	0.42
15	29.70	249.8	1.55	1.43	1.31	1.26	1.20	1.14	1.09	1.00	0.94	0.84	0.75	0.66	0.57	0.49
20	34.70	258.5	1.63	1.52	1.40	1.33	1.28	1.23	1.17	1.07	1.02	0.92	0.82	0.73	0.64	0.55
25	39.70	266.8	1.71	1.59	1.47	1.41	1.36	1.30	1.25	1.15	1.09	0.98	0.89	0.80	0.71	0.62
30	44.70	274.0	1.78	1.66	1.54	1.48	1.42	1.37	1.31	1.21	1.15	1.05	0.95	0.85	0.76	0.68
40	54.70	286.7	1.91	1.79	1.66	1.61	1.54	1.49	1.43	1.32	1.27	1.16	1.06	0.97	0.87	0.78
50	64.70	297.7	2.02	1.90	1.77	1.71	1.65	1.60	1.54	1.42	1.37	1.26	1.16	1.06	0.96	0.87
60	74.70	307.3	2.10	2.00	1.87	1.81	1.75	1.69	1.63	1.51	1.47	1.35	1.25	1.15	1.05	0.95
70	84.70	316.0	2.20	2.09	1.95	1.89	1.83	1.77	1.71	1.59	1.55	1.44	1.33	1.23	1.12	1.03
80	94.70	323.9	2.27	2.17	2.03	1.97	1.91	1.85	1.80	1.69	1.63	1.52	1.41	1.31	1.20	1.10
90	104.70	331.2	2.36	2.24	2.11	2.05	1.98	1.93	1.87	1.74	1.70	1.59	1.48	1.38	1.28	1.17
100	114.70	337.9	2.43	2.31	2.18	2.11	2.05	2.00	1.94	1.81	1.77	1.65	1.54	1.44	1.33	1.23
125	139.70	352.9	2.59	2.47	2.33	2.27	2.21	2.16	2.10	1.96	1.92	1.80	1.69	1.59	1.48	1.38
150	164.70	365.9	2.73	2.62	2.47	2.43	2.35	2.29	2.23	2.08	2.05	1.94	1.82	1.72	1.61	1.51
175	189.70	377.4	2.86	2.74	2.60	2.54	2.47	2.41	2.35	2.21	2.17	2.05	1.95	1.85	1.73	1.63
200	214.70	387.8	2.95	2.85	2.71	2.63	2.58	2.52	2.47	2.31	2.29	2.17	2.06	1.96	1.84	1.75

From Keenan and Keyes — Linear Interpolation. NOTE: Gauge pressure should be corrected for altitude.

Rate of pitch for steam ½" drop over 20-foot run.

Design Data

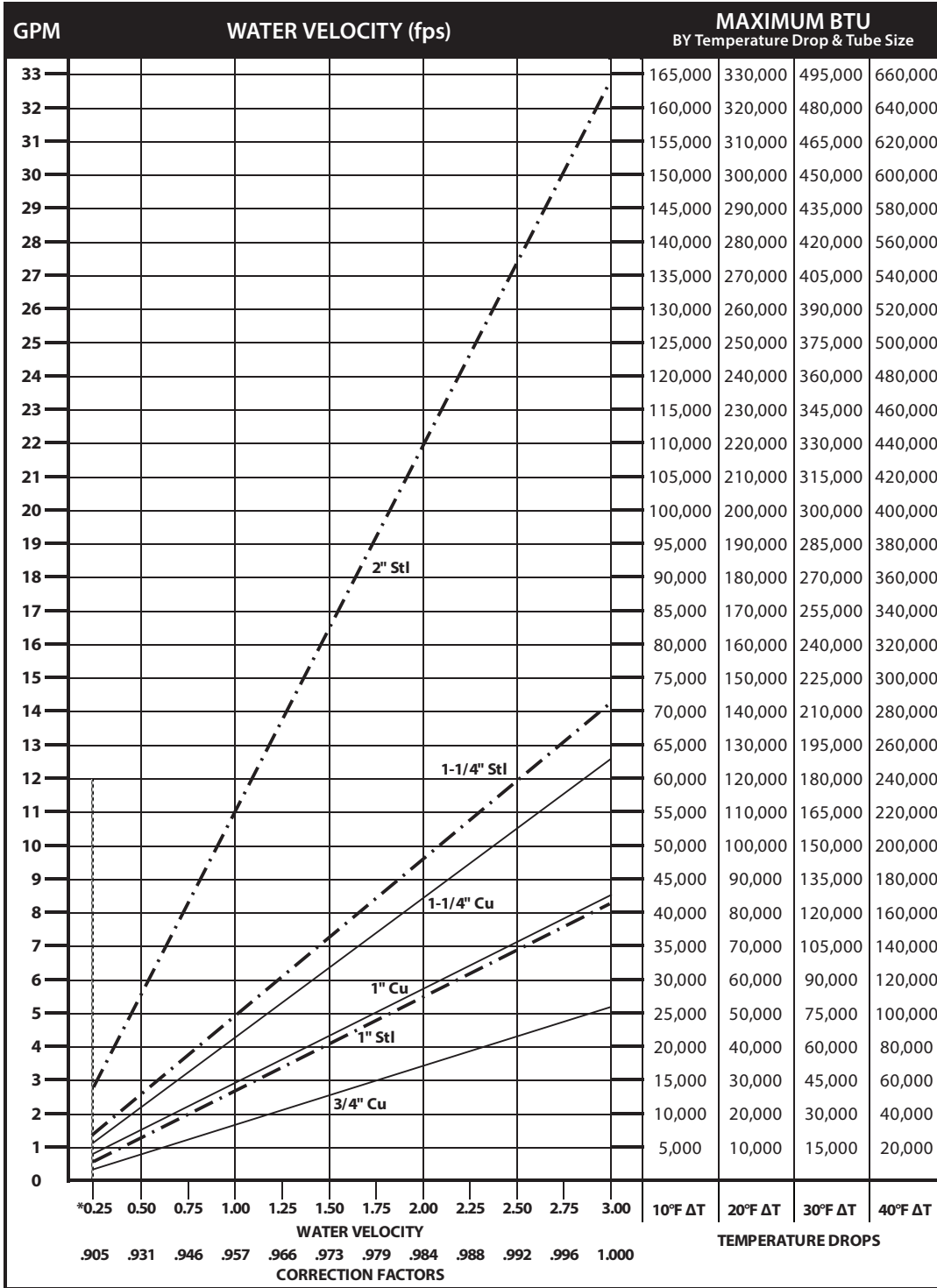

DYNAMIC FORMULAS

$$BTU = GPM \times 500 \times TD$$

$$GPM = \left(\frac{BTU}{500} \right) \div TD$$

$$TD = \left(\frac{BTU}{500} \right) \div GPM$$

*Do not design below .25 fps.

Pressure Drop at Given Water Velocities (Feet of Water per 100 ft. of pipe) based on Hazen - Williams calculation

Nominal Pipe Size	Water Velocity (ft/sec)											
	0.25	0.50	0.75	1.00	1.25	1.50	1.75	2.00	2.25	2.50	2.75	3.00
3/4" Copper	0.06	0.20	0.42	0.72	1.09	1.53	2.04	2.61	3.25	3.95	4.71	5.53
1" Copper	0.04	0.15	0.32	0.54	0.81	1.14	1.52	1.94	2.42	2.94	3.50	4.11
1 1/4" Copper	0.03	0.12	0.25	0.43	0.64	0.90	1.20	1.54	1.92	2.33	2.78	3.26
1" Steel	0.04	0.15	0.32	0.54	0.81	1.14	1.52	1.95	2.42	2.94	3.51	4.12
1 1/4" Steel	0.03	0.11	0.23	0.40	0.60	0.84	1.12	1.44	1.79	2.17	2.59	3.05
2" Steel	0.02	0.07	0.14	0.25	0.37	0.52	0.69	0.89	1.10	1.34	1.60	1.88

Design Data

GUARANTEED WORKING PRESSURES

- 1" IPS — 780 at Temperatures up to 650°F.
- 1-1/4" IPS — 660 at Temperatures up to 650°F.
- 2" IPS — 405 at Temperatures up to 650°F.
- 1-1/4" CU — 194 at Temperatures up to 300°F.
- 1" CU 204 at Temperatures up to 300°F.
- 3/4" CU 218 PSI at Temperatures up to 300°F.

MAXIMUM PRESSURES AT OTHER TEMPERATURES
ARE AVAILABLE UPON REQUEST.

Pipe Water Capacities and Quantities Circulated at Velocity of 3 Feet Per Second

Nominal Pipe Size	Pipe I.D. (inches)	Gals Per Lin. Ft.	GPM @ 3' per sec Velocity
3/4" Copper	0.835	0.028	5.12
1" Copper	1.077	0.047	8.52
1 1/4" Copper	1.315	0.071	12.70
1" Steel	1.075	0.047	8.49
1 1/4" Steel	1.395	0.079	14.29
2" Steel	2.115	0.183	32.85

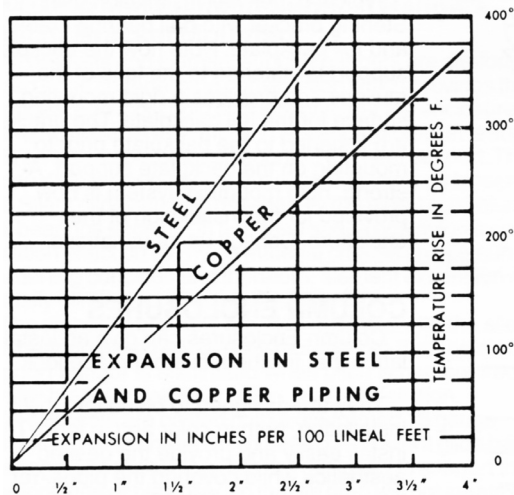

Glycol Correction Factors

Fluid Temperature 200°F

% Solution	Ethylene Glycol	Propylene Glycol
20	.952	.988
30	.921	.968
40	.888	.943
50	.852	.912

Fluid Temperature 180°F

% Solution	Ethylene Glycol	Propylene Glycol
20	.946	.982
30	.913	.961
40	.879	.934
50	.842	.902

Fluid Temperature 140°F

% Solution	Ethylene Glycol	Propylene Glycol
20	.934	.97
30	.898	.946
40	.861	.916
50	.821	.881

INLET VS. OUTPUT/BTUH CAPACITY REDUCTION

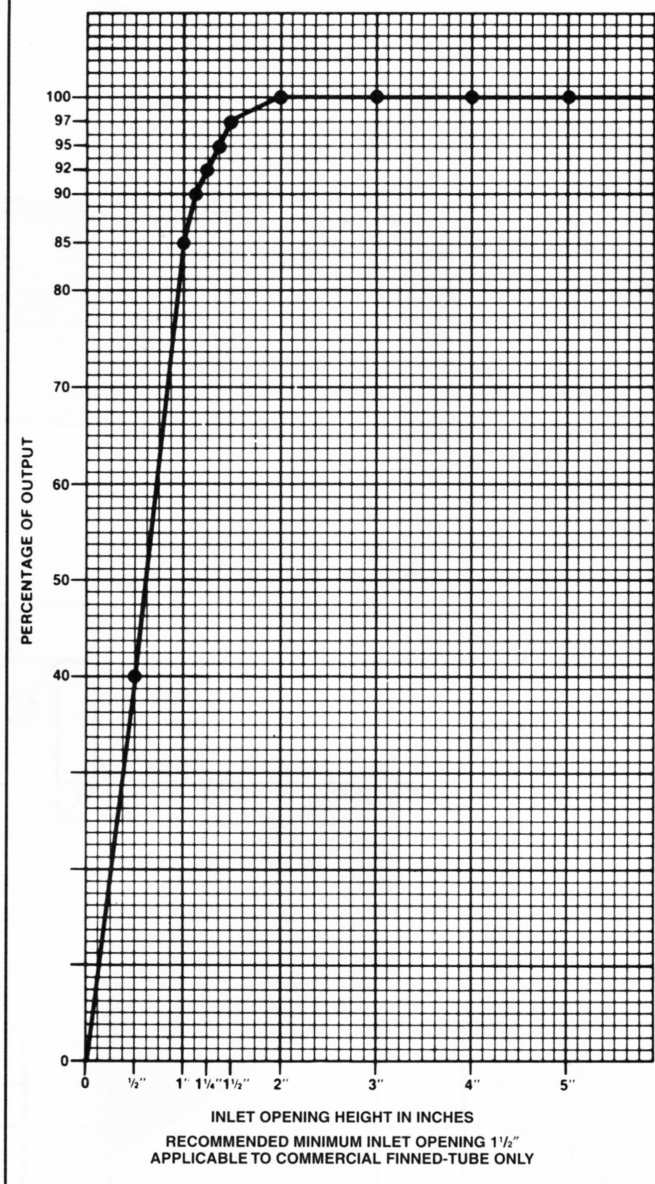

ALTITUDE FACTORS

Approximate factors for convective heat
value at varying altitudes

Altitude	Ferrous Units	Copper Alum. Units
Sea Level	1.000	1.000
1,000 ft.	.984	.969
2,000 ft.	.968	.938
3,000 ft.	.952	.908
4,000 ft.	.936	.878
5,000 ft.	.920	.850
6,000 ft.	.904	.822
7,000 ft.	.889	.795
8,000 ft.	.874	.768
9,000 ft.	.859	.743
10,000 ft.	.844	.718
15,000 ft.	.771	.603
20,000 ft.	.703	.502